



# OPMOS - Open Pit Mine Optimization System

Advanced Robotic Solution for Future Mining



This document contains proprietary information of Israel Aerospace Industries Ltd. and may not be reproduced, copied, disclosed or utilized in any way in whole or in part, without the prior written consent of Israel Aerospace Industries Ltd.

Unclassified / Commercially sensitive

# About Israel Aerospace Industry

- **Largest** Defense and Aerospace company in Israel
- Active in both the **defense and commercial** markets
- Employees: **15,000** (Engineers: 6,000)
- Cutting edge technologies and solutions for:  
**Space, Air, Land, Sea and Cyber**
  
- Revenues: 4 B\$
- Backlog: 9 B\$
- 80% export, worldwide in over **90 countries**
- Tel Aviv Stock Exchange





# IAI's Robotic Group Profile

- **Over 15 years experience** in developing and manufacturing State of the art Autonomous Vehicle Systems (AVS)
- **Operational deployments** and thousands of operation hours
- Providing a **wide range of Autonomous robotic solutions** for Defense, HLS and Commercial markets
- **Proven past experience**



# Robotic System advantages



## Robotic 3D's (Dangerous, Dull, Dirty)



Unclassified / Commercially sensitive





# OPMOS overview

- Advanced **Robotic solution** for Future Mining
- Easily adapted to a wide variety of **mining machinery and haul trucks**
- **Accurate navigation solution**
- **Obstacle detection and avoidance**
- **Command & control center** for planning, execution and real-time fleet management
- Supports **full mining life-cycle**, from loading to dumping
- System components are designed for durability in **harsh mine environments**



# OPMOS Benefits

- Improves **production performance** (+15%), reduces waiting time (-20%)
- Enables continuous, unmanned activity in all-weather conditions for **24/7 operation**
- **Reduces operational costs**, such as: human resources (-5%), fuel consumption (-10%), tire wear (-12%), and platform maintenance (-14%)
- **Improves monitoring** and control of planned vs. actual mine performances **Increases safety**
- Optimizes driving for **cleaner environment**

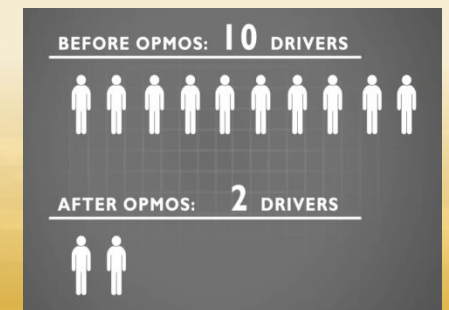
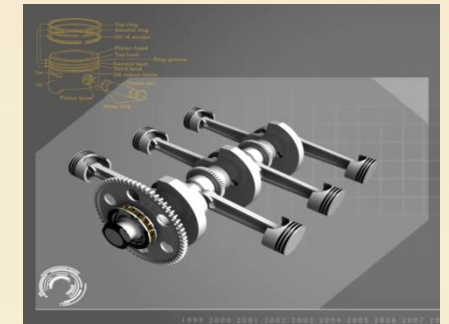

\* Parreira, J and Meech, J. 2010. Autonomous vs manual haulage trucks - how mine simulation contributes to future haulage system developments. CIM Meeting 2010, Vancouver-BC, Canada.

\*\* J. Parreira and J.A. Meech, 2011. "An interactive simulation model of human drivers to study autonomous haulage trucks", Procedia Computer Science, 6

\*\*\* S. Brundrett, P.Eng, 2014. Industry analysis of autonomous mine haul truck commercialization", University of British Columbia

Unclassified / Commercially sensitive





# OPMOS – Robotic haulage process

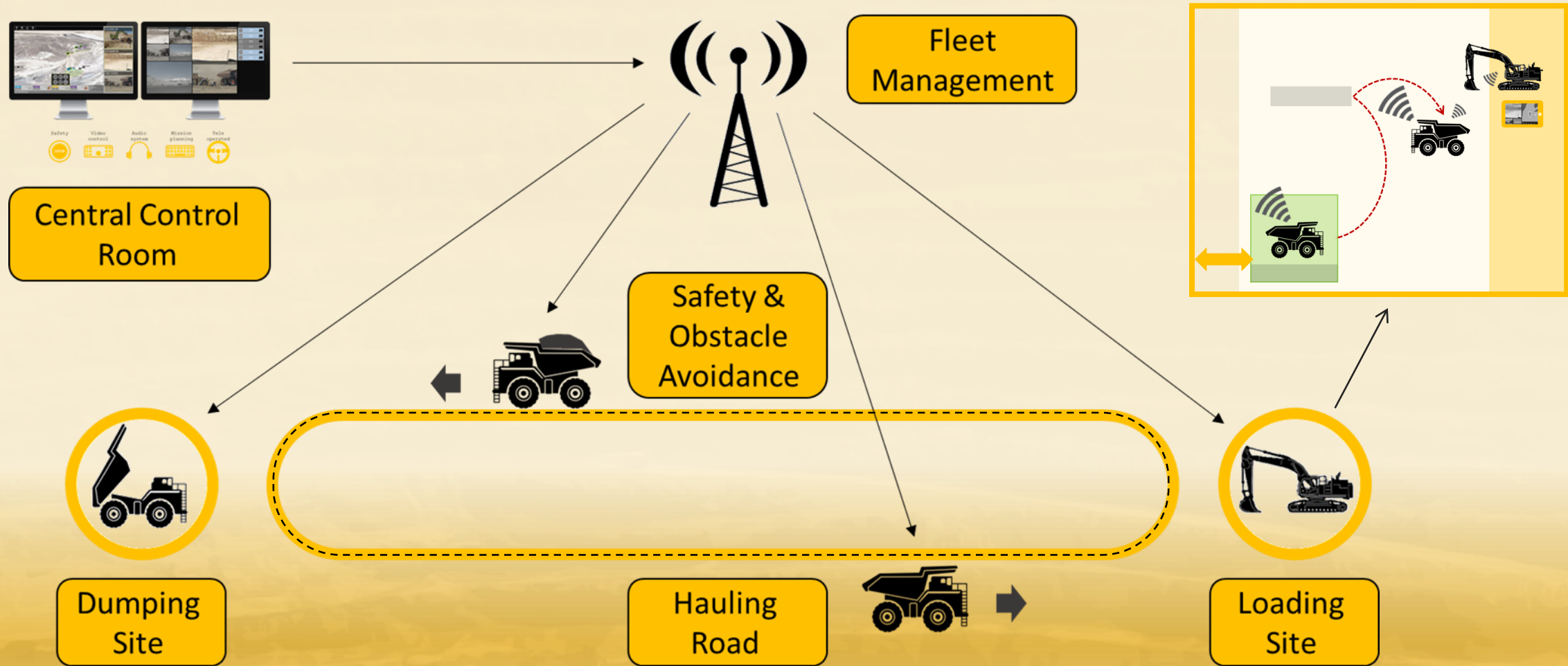

Unclassified / Commercially sensitive



# OPMOS – Platform Robotization

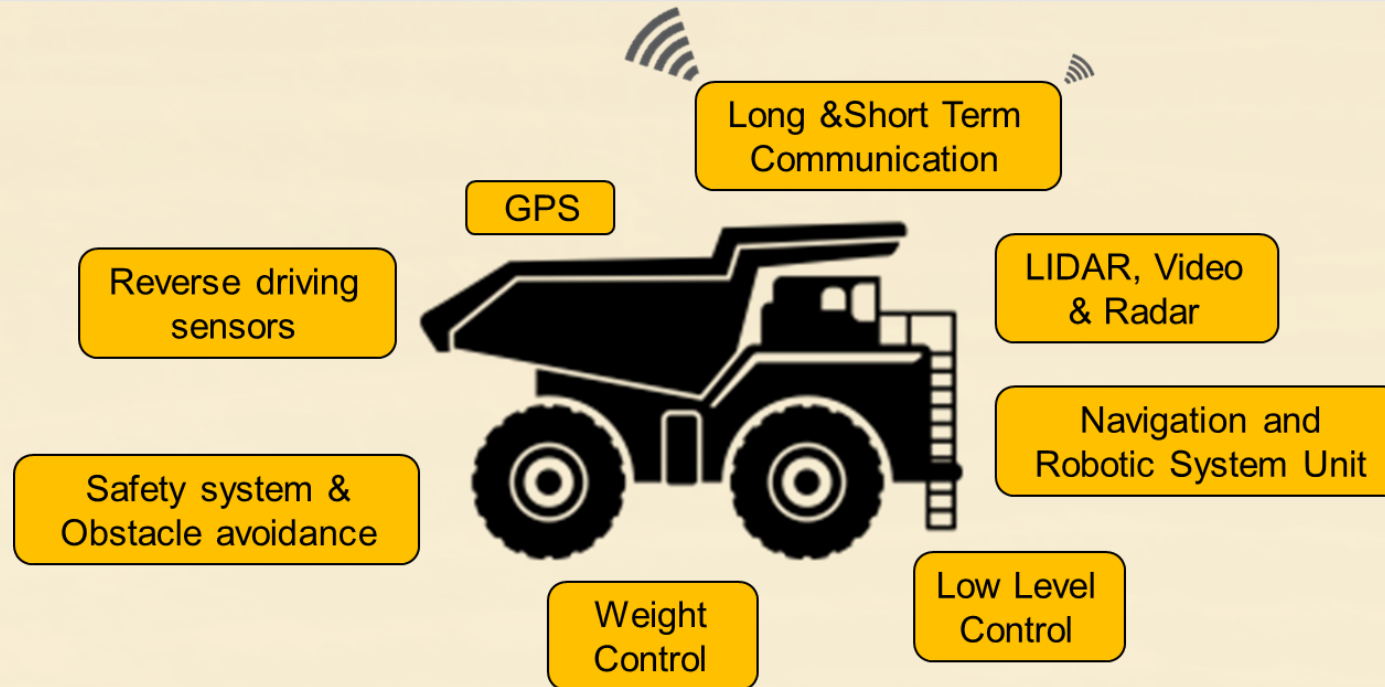

Medium & low Level Control



Navigation & localization

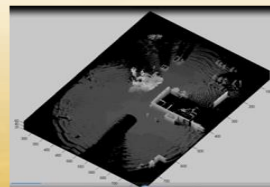

Perception

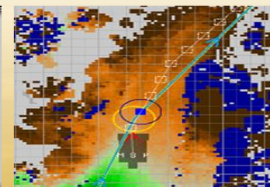

Path Planning



Operation center

OPMOS solution is based on IAI's proven ROBOTIC KIT capabilities

Unclassified / Commercially sensitive





# OPMOS - Fleet management

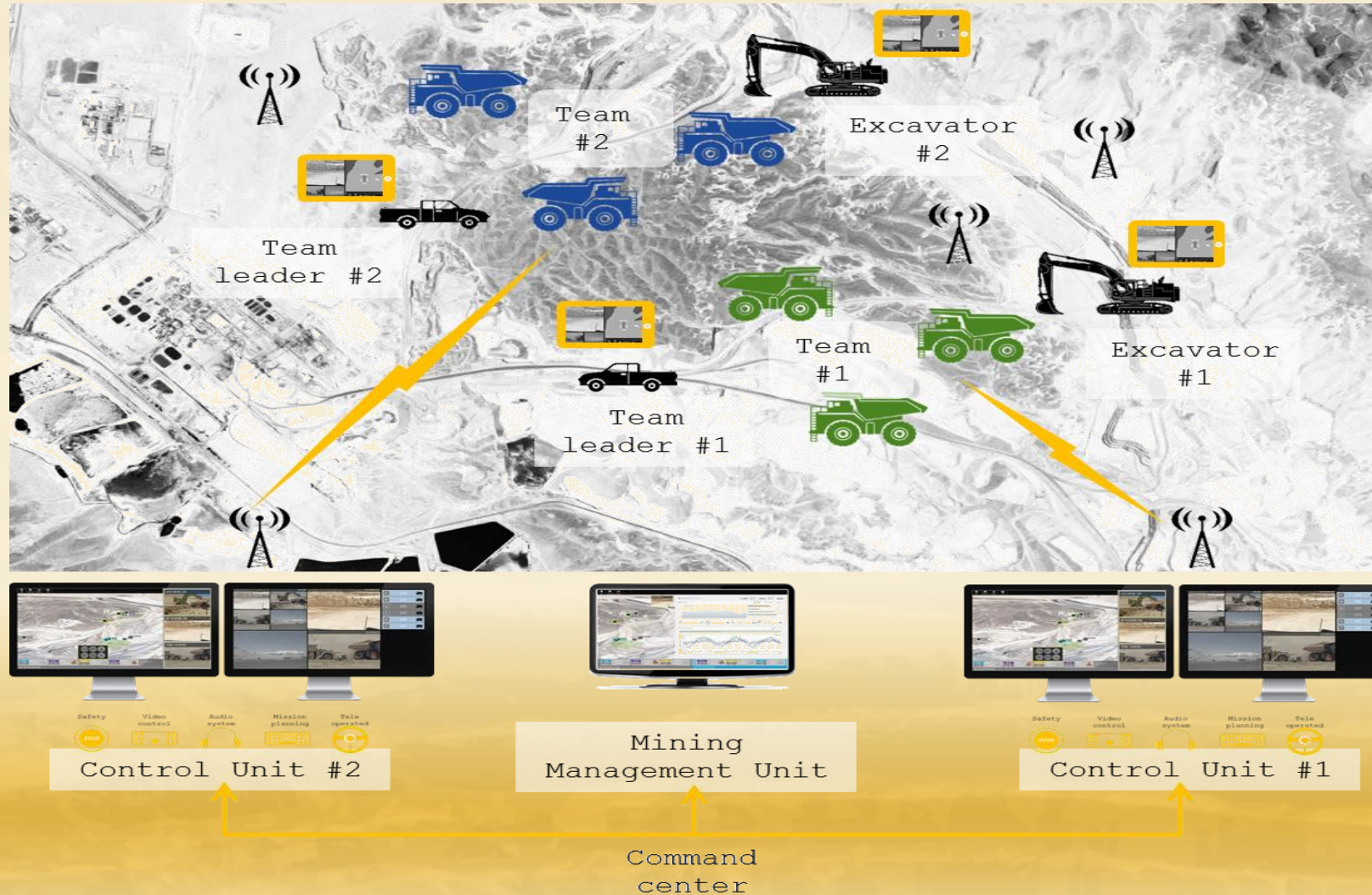

Unclassified / Commercially sensitive



# OPMOS Fleet Management & Optimization



Real time information & Data analytics to Increase operation productivity and efficiency





# OPMOS Implementation

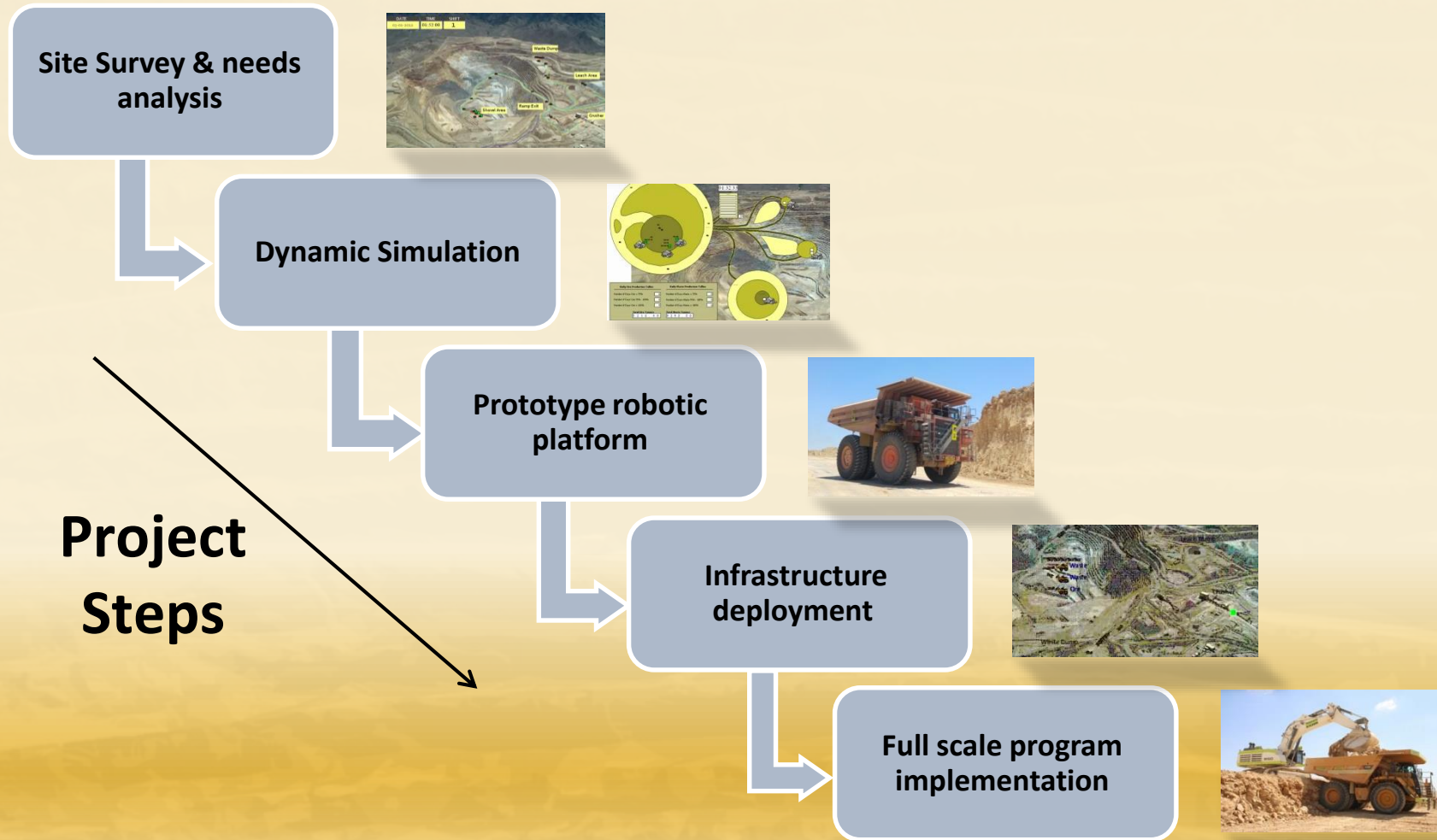

# OPMOS – Optimize your mine

Thank you.

